



David Bird

TRICK ONE



AN HONORS eBook FROM MASTER POINT PRESS

Text © 2018 David Bird

All rights reserved.

Honors eBooks is an imprint of Master Point Press. All contents, editing and design (excluding cover design) are the sole responsibility of the author.

Master Point Press
214 Merton St. Suite 205
Toronto, Ontario, Canada
M4S 1A6
(647) 956-4933

Email: info@masterpointpress.com

Websites: www.masterpointpress.com
www.bridgeblogging.com
www.teachbridge.com
www.ebooksbridge.com

ISBN: 978-1-55494-591-7

Cover Design: Olena S. Sullivan/New Mediatrix

1 2 3 4 5 6 21 20 19 18

CONTENTS

Introduction	4
PART I Declarer play	
1. Avoidance play at trick one	6
2. Winning in the right hand	15
3. Should I hold up with one stopper?	23
4. Preserving trump control	29
5. Should I finesse at trick one?	34
6. Entry planning	41
7. Should I hold up with two stoppers?	48
8. Setting up a squeeze	53
9. Playing safe at trick one	64
10. Avoiding a blockage	69
11. Playing the right card from dummy	74
12. Handling A-and-J combinations	81
13. Should I ruff the first trick?	88
14. Blocking the defenders' suit	94
15. Setting up an endplay	99
16. Deceptive plays	106
PART II Defensive play	
17. The right card in third seat	114
18. Managing defensive entries	121
19. Helpful signaling	126
20. Unblocking in third seat	134
21. Disrupting declarer's plan	139
22. Maintaining communications	144
23. Deceptive defense	149
PART III Test your declarer play	
24. Quiz on declarer play	156
PART IV Test your defense	
25. Quiz on defensive play	199

Introduction

Suppose, by some computer magic, you could analyze all the bridge contracts ever played. Whenever declarer went down in a contract that should have been made, the computer program would note the trick on which the critical error occurred. It would do the same every time the defenders made a mistake that allowed declarer to succeed. Eventually the program would produce a table, giving the percentage of contracts that were given away on each of the 13 tricks.

No-one ever gives a contract away on trick thirteen, of course. You can be sure that the very first trick is the one where most declarers go astray. It's the same story with the defenders. By the time the first trick has been turned, they will often have surrendered any chance of beating the contract.

Play perfectly at trick one and you will be some way along the road to becoming an expert player. That is the aim of this book. We will look at the most important techniques available to you on the first trick, both as declarer and as a defender.

The book ends with a 44-problem quiz section, so you can check how much your play has improved!

DB

My thanks go to Linda Lee, Canadian international and wife of the publisher, who gave me the idea for this book. Many thanks also to Tim Bourke, a renowned composer of 'deals with a twist', who has sent me countless great constructions over the years. Finally, I am indebted to my friends: Simon Cochemé, Maureen Dennison and Dominic Connolly, who kindly offered to proof-read the book and made many valuable suggestions in addition.

PART I

Declarer play

1

Avoidance play at trick one

The term ‘avoidance play’ may sound intimidating. In truth, it means little more than attempting to keep the dangerous defender off lead. Look at this deal, where you do not want East to win the lead:

N-S Vul.	♠ A 6 2		
Dealer South	♥ Q 6 3 2		
	♦ 9 6 3		
	♣ Q 10 4		
♠ K Q J 8 7 4		♠ 10 9	
♥ 7		♥ 10 5 4	
♦ A Q 2		♦ J 10 7 4	
♣ 9 8 7		♣ 6 5 3 2	
	♠ 5 3		
	♥ A K J 9 8		
	♦ K 8 5		
	♣ A K J		
West	North	East	South
–	–	–	1♥
1♠	2♥	pass	4♥
all pass			

West leads the ♠K and down goes the dummy. You can see one spade loser and three more potential losers in diamonds. What plan will you make?

West is likely to hold the ♦A after his overcall. If he began with ♦A-x, he will have to play the ace on the second round and your ♦K will live to score a trick. However, there is a better way to play the contract.

If West holds the six spades, you can endplay him. Since you will have to lose a round of spades and would not like East to win this (and switch to a diamond), you should allow West’s ♠K to take the first trick. You win the spade continuation with dummy’s ace and draw trumps in three rounds. You then play three rounds of clubs, ending in the dummy. These cards remain:

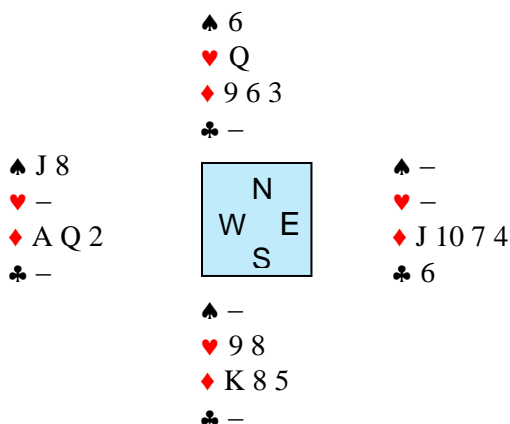

When you lead the ♠6, East discards his club. You then throw the ♦5 (a loser-on-loser play). West has to win the trick and must assist you with his return. A diamond will allow you to make the ♦K and a spade will give you a ruff-and-sluff.

Without your duck on the first trick, you would have gone down. East would have won the second round of spades and switched to the ♦J. Not a pleasant thought!

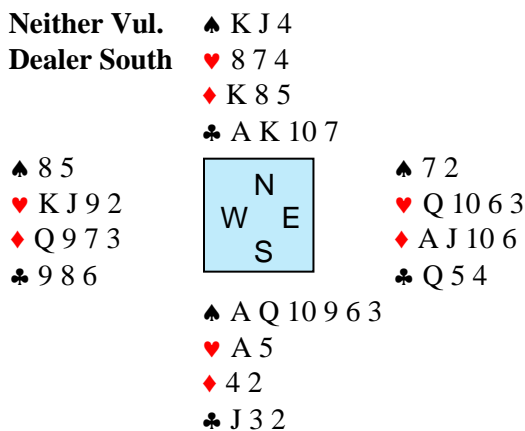

West	North	East	South
-	-	-	1 ♠
pass	2 ♣	pass	2 ♠
pass	4 ♠	all pass	

How would you play 4♠ when West leads the ♥2 to East's queen?

You have six tricks in spades and one in hearts. Even if a club finesse loses to East, you will then be sure of three club tricks, bringing the total to ten. Can anything go wrong?

Yes indeed, as was demonstrated by the original declarer. Suppose you win the first trick with the ♥A, draw trumps in two rounds and play a club to the ten. When East wins with the ♣Q he can cross to partner's hand with a heart. Provided West reads the situation, a diamond switch through dummy's king will beat the contract. East should return the ♥3, his original fourth-best. West will then know that only one heart trick can be taken. (If East held two hearts, South would hold four and would have rebid 2♥.)

How can you avoid this fate as declarer? To make sure that West cannot gain the lead to play a diamond, you must allow East's ♥Q to win the first trick. East will then have no way to reach his partner's hand.

Both Vul. ♠ A Q 9
Dealer South ♥ 7 6 4
 ♦ A 6 3 2
 ♣ A K 7

♠ 8 3 ♥ A 8 3 ♦ Q 10 7 ♣ Q J 10 3 2	<div style="border: 1px solid black; padding: 5px; width: fit-content; margin: 0 auto;"> N W E S </div>	♠ 6 5 ♥ Q J 10 9 ♦ K J 5 ♣ 9 8 6 5	
--	--	---	--

♠ K J 10 7 4 2
 ♥ K 5 2
 ♦ 9 8 4
 ♣ 4

West	North	East	South
–	–	–	2♠
pass	4♠	all pass	

West leads the ♣Q and you pause to make a plan, let's hope! You have three potential heart losers and two in diamonds. There is one easy discard on the ♣A-K but how can you avoid losing four tricks when the ♥A lies over the king?

If you have not seen this type of deal before, it may be difficult to spot the answer. When diamonds are 3-3, you can set up a 13th card in that suit for a discard. You must achieve this without allowing the danger hand (East, who can switch through the ♥K) to win the lead. How can this be done?

You must duck the ♣Q, leaving the safe West hand on play. If he switches to a trump, you win with the ♠9 and play the two top clubs,

throwing two diamonds from your hand. You then play the $\spadesuit A$ and ruff a diamond in your hand. A trump to the queen and a second diamond ruff bring good news. Diamonds are 3-3 and the humble $\spadesuit 6$ is now established. You return to dummy with the $\spadesuit A$ and discard a heart on the good diamond.

When you seek an overtrick later, leading towards the $\heartsuit K$, West wins with the ace and you are held to ten tricks. Are you disappointed? Not at all! It means that your exotic play at trick one was the only way to make the contract.

The game would have gone down on the lead of a trump or a diamond. Even an unthinkable low club would have worked. It is just so annoying, as a defender, when you are dealt an obvious opening lead from a sequence and this happens to give the contract away. Mind you, it will only do so here if the declarer knows a thing or two about avoidance play.

Right, would you have made this next one?

Both Vul. \spadesuit K J 7 2
Dealer South \heartsuit 10 9 2
 \diamondsuit A 5
 \clubsuit J 7 6 2

\spadesuit 10 8 4 \heartsuit K 7 4 \diamondsuit J 10 9 7 4 \clubsuit K 8	<div style="border: 1px solid black; padding: 5px; width: 60px; margin: 0 auto;"> <div style="display: flex; justify-content: space-between; padding: 2px;"> N </div> <div style="display: flex; justify-content: space-between; padding: 2px;"> W E </div> <div style="display: flex; justify-content: center; padding: 2px;"> S </div> </div>	\spadesuit Q 9 6 3 \heartsuit J 8 6 5 3 \diamondsuit K 6 2 \clubsuit 10	
---	---	--	--

\spadesuit A 5
 \heartsuit A Q
 \diamondsuit Q 8 3
 \clubsuit A Q 9 5 4 3

West	North	East	South
–	–	–	1 \clubsuit
pass	1 \spadesuit	pass	2NT
pass	3NT	all pass	

West leads the $\diamondsuit J$ against 3NT and we will see first how the original declarer misplayed the hand. ‘Small, please,’ he said.

East won with the $\diamondsuit K$ and made a bright switch to the $\heartsuit 5$. Declarer finessed the $\heartsuit Q$, losing to the king, and back came another heart to remove his ace. Hoping for the best, declarer crossed to the $\diamondsuit A$ and ran the $\clubsuit J$. He was not amused when this lost to the West’s king and the defenders claimed three more heart tricks to put the game two down.

Going down in any contract can be a painful experience. This deal was

even worse because the contract was cold if declarer had stopped to make plan at the start.

Correct play is to rise with the dummy's $\heartsuit A$ at trick one, giving East no chance to find a possibly damaging heart switch. Declarer can then run the $\clubsuit J$ into the safe (West) hand, not caring whether the finesse wins or loses. When West wins with the $\clubsuit K$ and returns another diamond (nothing else is better), East wins with the $\heartsuit K$ and declarer makes an overtrick.

Both Vul. \heartsuit K Q 3 2
Dealer South \heartsuit A J 10 9
 \diamondsuit 7 5 3
 \clubsuit A 6

\heartsuit 8 \heartsuit K 8 6 3 \diamondsuit A Q 4 \clubsuit K Q J 9 3	<div style="border: 1px solid blue; padding: 5px; width: fit-content; margin: 0 auto;"> N W E S </div>	\heartsuit 5 \heartsuit Q 5 2 \diamondsuit J 10 9 2 \clubsuit 10 8 7 5 2
---	--	---

\heartsuit A J 10 9 7 6 4
 \heartsuit 7 4
 \diamondsuit K 8 6
 \clubsuit 4

West	North	East	South
—	—	—	3 \heartsuit
dbl	4 \heartsuit	all pass	

West leads the $\clubsuit K$ and you can see one loser in hearts and three potential losers in diamonds. All will be well if West holds the $\heartsuit K$ -Q because you will be able to lose a heart trick to the safe hand, setting up some discards. What can be done if East holds one of the heart honors?

It's easy enough when you can see all four hands (and recall the title of the chapter!) but would you have spotted the right play at the table? You need to duck the first trick, allowing the safe (West) hand to win with the $\clubsuit K$. On this trick East will have the chance to give a suit preference signal. If he held the $\heartsuit K$, he would follow with the $\clubsuit 2$ and the defenders would then score three diamond tricks to beat the game. Here, he will signal with the $\clubsuit 8$, a high club to show an honor in the higher of the red suits.

You win the low heart switch with the $\heartsuit A$, draw trumps with the king and discard your $\heartsuit 4$ on the $\clubsuit A$. You then lead the $\heartsuit J$, ruffing when East produces the $\heartsuit Q$. You return to dummy with the $\heartsuit Q$ and lead the $\heartsuit 10$, discarding a diamond loser. West wins with the $\heartsuit K$ and has no good return. A heart to dummy's $\heartsuit 9$ will let you discard a diamond. If he returns a

diamond instead, you will score the $\heartsuit K$. A club return will be no more successful, giving you a ruff-and-sluff. Brilliant!

Your play in hearts is known as a ‘double ruffing finesse’. You could achieve it only if you planned the play when dummy went down and saw the need to duck at trick one.

E-W Vul.	\spadesuit J 8 7 4		
Dealer South	\heartsuit K J 5		
	\diamondsuit 6 4 3		
	\clubsuit K J 3		
\spadesuit –		<div style="border: 1px solid black; display: inline-block; padding: 5px; text-align: center;">N W E S</div>	\spadesuit 9 2
\heartsuit A 10 9 7 6 3			\heartsuit Q 8 4 2
\diamondsuit A 10 5			\diamondsuit Q J 8 2
\clubsuit 10 9 7 5			\clubsuit Q 8 6
	\spadesuit A K Q 10 6 5 3		
	\heartsuit –		
	\diamondsuit K 9 7		
	\clubsuit A 4 2		

West	North	East	South
–	–	–	1 \spadesuit
2 \heartsuit	2 \spadesuit	3 \heartsuit	4 \spadesuit
all pass			

What is your plan for 4 \spadesuit when West leads the $\clubsuit 10$?

Despite your splendid hand, matched by a full 9 points in the dummy, you are in danger of losing one club trick and three diamonds. You should aim for an endplay on West. You would like to throw him in with the $\heartsuit K$ to his ace on the third round, discarding a diamond from your hand. Providing you have eliminated the club suit, he would then have to give you a trick with the $\diamondsuit K$ or concede a ruff-and-sluff in hearts. The question is: can you eliminate clubs without allowing East on lead?

Would the learned author of this book have spent a good while composing this deal if the answer was ‘No’? You should play low from dummy on the club lead, East playing the $\clubsuit 6$ and... low from your hand!

The safe West hand is left on lead. When he plays another club you win in your hand and draw trumps with the ace and jack. You then ruff the $\heartsuit 5$, return to dummy with the $\clubsuit K$ and ruff the $\heartsuit J$. Finally, you cross to a trump and lead the $\heartsuit K$, throwing a diamond. West is endplayed as we foresaw at the start.

Sometimes you see a line of play that will give you a good chance of making the contract. You start on it right away, without bothering to look for anything better. That's what happened on this deal:

Both Vul.	♠ Q 10 9 6 5 4 2										
Dealer South	♥ 3										
	♦ 9 7 2										
	♣ J 10										
♠ 8	<table border="1" style="border-collapse: collapse; width: 40px; height: 40px; margin: auto;"> <tr><td></td><td style="text-align: center;">N</td><td></td></tr> <tr><td style="text-align: center;">W</td><td style="text-align: center;">E</td><td></td></tr> <tr><td></td><td style="text-align: center;">S</td><td></td></tr> </table>		N		W	E			S		♠ 7
	N										
W	E										
	S										
♥ K Q 10 8 4		♥ 9 6 5 2									
♦ A 10 5		♦ Q J 8									
♣ 9 7 4 2		♣ K Q 8 5 3									
	♠ A K J 3										
	♥ A J 7										
	♦ K 6 4 3										
	♣ A 6										
West	North	East	South								
–	–	–	2NT								
pass	3♥	pass	3♠								
pass	4♠	all pass									

The original declarer won the ♥K lead with the ace. His plan was to eliminate the black suits, ruff one heart and then throw West on lead with the ♥J to the ♥Q, discarding a diamond loser from dummy. West would then have to open the diamond suit or concede a ruff-and-sluff.

Declarer crossed to the ♠9 and led the ♣J. His intention was to run this card to West, the safe hand who could not attack diamonds effectively. All would have been well if West had held one or both of the missing club honors. (If East covered with his sole honor on the first round, declarer would win and concede the second round to West). The ♣J was covered by the queen and ace. East won the second club with the king and defeated the contract with a switch to the ♦Q.

Do you see how declarer could have guarded against this hostile lie in the minor suits? He should have ducked the opening lead, allowing the ♥K to hold. He would win the club switch, draw trumps and discard dummy's remaining club on the ♥A. He could then eliminate clubs with a ruff, giving East no chance to gain the lead. After reaching his hand with a trump, he would throw West on lead with the ♥J to the queen, leaving him endplayed.

We will end the chapter with a deal where an opponent's opening bid gives you some useful information:

N-S Vul.	♠ 10 5 3										
Dealer East	♥ A 9 6 2										
	♦ A K Q 9 5 2										
	♣ –										
♠ J 7 2	<table style="margin: auto; border-collapse: collapse;"> <tr><td></td><td style="text-align: center;">N</td><td></td></tr> <tr><td style="text-align: center;">W</td><td style="text-align: center;">E</td><td></td></tr> <tr><td></td><td style="text-align: center;">S</td><td></td></tr> </table>		N		W	E			S		♠ 9 6
	N										
W	E										
	S										
♥ K		♥ Q J 8 7 5 3									
♦ J 7 6 3		♦ 10 8									
♣ J 8 7 5 4		♣ A 6 2									
	♠ A K Q 8 4										
	♥ 10 4										
	♦ 4										
	♣ K Q 10 9 3										

West	North	East	South
–	–	2♥	2♠
pass	5♣	pass	5NT
pass	6♠	all pass	

North bids 5♣, Exclusion RKCB to ask for keycards outside the club suit, and is happy to hear of your ♠A-K-Q. Not liking to be too greedy, he settles for 6♠. How will you tackle this contract when West leads the ♥K?

If you win with the dummy's ace, you will need a fair amount of luck to make the slam. You would go down on the lay-out shown. East's 2♥ opening makes it likely that he holds six hearts, leaving the ♥K as a singleton. The best line by a distance is to play low from dummy at trick one.

Suppose West switches to a club, which you ruff in dummy. You play the ♦A and ruff a diamond in your hand, everyone following. You draw trumps, happy to see the suit break 3-2, and return to the dummy with the ♥A. Finally you discard your four remaining clubs on the good diamonds.

The play is similar if West switches to a diamond at trick two. You win and ruff a diamond in your hand. You need a club ruff to bring your total to twelve. After this necessary move, you draw trumps and claim the same twelve tricks that we saw before.

Points to remember

- Playing in a suit contract, with something like A-x opposite x-x-x in the suit led, it may pay you to duck the first trick to a safe defender.
- Ducking may kill the defenders' later communication in the suit, keeping the 'danger hand' off play.
- With such as A-10-x in the dummy, you can duck a king lead if RHO (your right-hand opponent) is the danger hand. You may instead duck the lead of a lower card to the defender in third seat, when LHO is the danger hand.
- With A-x-x opposite a singleton, or A-K-x opposite a doubleton, ducking the first round may allow you to set up a different suit after taking a discard. With A-x-x-x-x opposite K-x-x, your earlier duck might allow you to discard from the 3-card holding and then establish the suit without letting the danger hand on lead.
- Ducking in a suit contract can prevent the defenders from scoring a ruff or trump promotion in the suit led.

THE RIGHT FIRST MOVE

A huge percentage of failing contracts go down because declarer did not play optimally on the first trick. Similarly, countless contracts are allowed to slip through because the defender in third seat made the wrong play.

With 125 instructive deals, David Bird covers all aspects of the first card played from dummy, the first move by the defender in third seat and the card chosen by declarer from his hand.

Parts I and II contain chapters on declarer play — with topics such as Avoidance Play, Winning in the Right Hand, Blocking the Defenders' Suit, Setting up a Squeeze, Deceptive Play and Setting up an Endplay — and defense — with topics including Unblocking, Managing Defensive Entries, Deception, Signaling and Disrupting Declarer's Plan.

Parts III and IV contain 44 problems, with each solution triggered by a necessary play at trick one.

Perfect your cardplay at trick one and you will be difficult to beat!



DAVID BIRD (Southampton, UK) is the world's most prolific bridge writer. A six-time American Bridge Teachers' Association Book of the Year award winner, he has over 135 books to his name. David's columns appear regularly in the ACBL *Bridge Bulletin*, *A New Bridge Magazine*, *English Bridge*, *Australian Bridge* and other periodicals around the world. He is married with a daughter, a son and two grandchildren.

